

Why Single Frequency Networks Using ATSC-8VSB Modulation Cannot Provide DTV Service Comparable with that of a Single Antenna on a Tall Tower

Oded Bendov

Introduction

In this document we define signals as independent transmissions from two or more on-channel transmitters, each with independent noise spectra. Echoes are defined as passive reflections generated by one or more signals. The noise spectrum of the echo is correlated with the noise spectrum of its signal.

In an on-channel distributed transmitters system (DTS), of which a single frequency network (SFN) is a special case¹, the relative magnitude of signals will be near 0dB over a wide area. The relative magnitude of the echoes is typically less than 0dB relative to their signals, and their delay is typically less than 10μsec. The ATSC defines a -6dB echo as “moderate.”

The reception of the single-carrier ATSC format is prone to outage where strong and dynamic echoes exist. The echo environment created by a single transmitter from a tall tower, 1200 feet on average, can be described as Rician where the power of the dominant signal is stronger than the echo power.

The echo environment of SFN is entirely different. Because the height of SFN towers is expected not exceed 300 feet, the echo environment in the covered area would be characterized as Rayleigh. This means that in urban environments with short towers and without line-of-sight to the receive antenna, the interfering signals, not just their echoes, would be severe over the entire coverage area. In a Rayleigh environment, well known in mobile communication systems using short towers, the echo power is essentially equal to the dominant signal power and the directions of arrival, signals or echoes, would be random. In such environment, directional receive antennas cannot, in general, discriminate against the reception of significant and undesired echo or signal power.

Designers and researchers have focused on laboratory tests that have specifically ignored some of the more insidious causes of reception loss. That has led to a general endorsement of SFN/DTS systems that, at best, should be restricted to special areas, such as those that provide terrain shielding between transmitters. For example, the relative phase between any two echoes whose relative delay is less than two symbol periods have been ignored. Also ignored in the laboratory tests is the cancellation of the Pilot by static and dynamic echoes. It has been shown² that the .05Hz Doppler shifted signal or echo, often used in the laboratory tests, is inadequate test of Pilot self-interference. These issues will be discussed in this paper.

A. Loss of Synchronization and Spectral Distortion

Successful decoding of the ATSC-8VSB signal is a two-step process, starting with a sufficiently strong desired signal power. As shown in the block diagram of **Figure 1**, the carrier's frequency and phase, offset by echoes, must be restored. Then, the equalizer must remove the inter-symbol interference. If either fails, decoding fails.

¹ SFN is defined as a network of transmitters designed so that all transmitters have approximately the same lower ERP and antenna height but not necessarily same antenna pattern. In contrast, DTS would consist of one central high-power transmitter whose high-gain antenna is as high as possible and one or more on-channel, lower-power transmitters on lower height towers.

² Private communication of the test results at C. Rhodes' laboratory. To be published.

Originally, the pilot at .31MHz above the lower edge of the channel was used for frequency and phase recovery. At that time, significant reduction in the pilot's level by 10dB or more was a serious problem. Later, only phase recovery required a pilot. More recently³, carrier recovery using the field sync signal has been proposed. The proposed pilot-less carrier recovery is limited shift by dynamic echoes to a maximum carrier shift of $\pm 150\text{kHz}$.

An undesired static echo or signal at a specific delay will cause the pilot's magnitude to change up or down depending on its relative phase shift by the undesired. In the extreme, the undesired echo or signal may arrive at 180° and at an equal level (0dB) relative to the desired pilot. That will cancel the pilot. This self-interference of pilots, generated by signals or echoes, static and dynamic, results in loss of the desired pilot's power to below a required minimum level, which varies with the type of tuner². If the interference is dynamic, i.e. by undesired Doppler shifted echoes or signals, the pilot's instantaneous frequency will be shifted. The \pm Doppler shifting of the pilot is illustrated in **Figure 2**. Analysis of the pilot's instantaneous frequency shift as a function of interference level is presented in **Section B 2**.

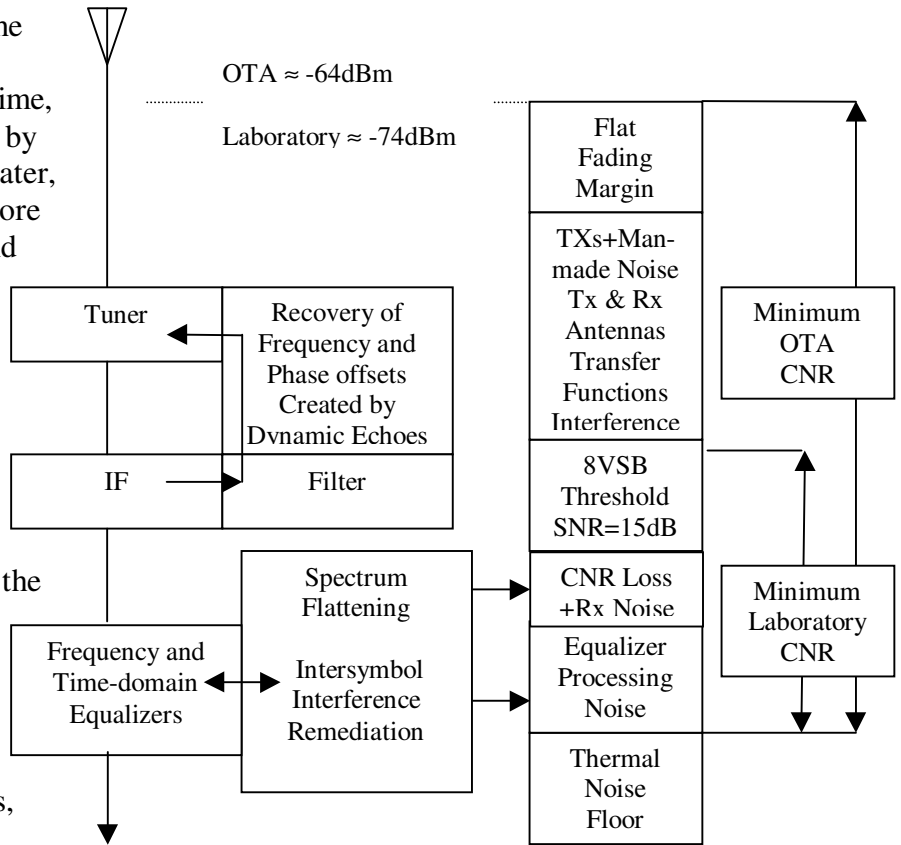

Figure 1: Synchronization and Equalization of ATSC 8VSB Signals

If the frequency shift is beyond the $\pm 150\text{kHz}$ passband of the pilot's filter shown in **Figure 1**, or if the convergence speed of the recovery loop is not fast enough, carrier recovery and thus the synchronization of the received signal will fail. For these reasons, strong dynamic undesired signals and echoes which cause significant frequency and phase shifts would be most harmful.

If the frequency and phase recovery is successful, the equalizer will attempt to flatten the spectrum by attenuating all undesired signals and echoes. To accomplish that task an ideal equalizer would have an infinite number of taps and zero time response. Ideal equalizers do not exist, and the undesired signals and echoes are either attenuated or not depending on the performance specifications of the equalizer. As shown in **Figure 1**, the attenuated and unattenuated echoes and undesired signals become added noise.

Successful synchronization and equalization requires a minimum of signal level (CNR) and a minimum of SNR. The SNR is defined as $(\text{Total Symbol Power})/(\text{Rx Noise}+\text{Equalization Noise})$.

³ Jingson Xia, "A Carrier Recovery Approach for ATSC Receivers," IEEE Trans. on Broadcasting, Vol. 54, NO.1, March 2008.

The Threshold SNR in a distortion-free channel (i.e. no Equalization Noise) is 15dB. The thermal noise floor is $-106.2\text{dBm} + \text{NF}$. If the NF is 7dB, the thermal noise floor is -99.2dBm . Therefore, the minimum signal power in a laboratory setting is $-99.2\text{dBm} + 15\text{dB} = -84\text{dBm}$. This level does not account for the noise that would be generated by the attenuation and processing of undesired signals and echoes.

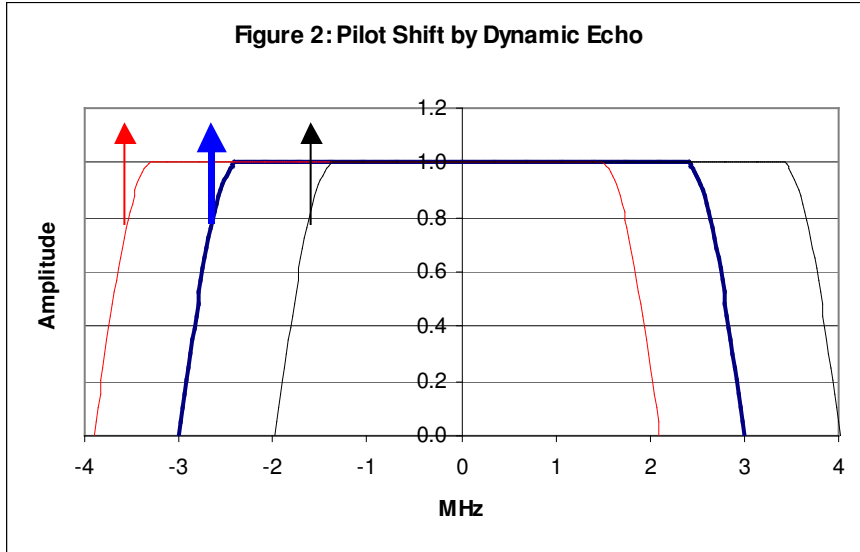

As shown in **Figure 1**, the required minimum RF signal power level is directly related to the required minimum CNR. The CNR is defined as (Total Signal Power in 6MHz)/(Rx Noise Floor). There is a substantial difference between the minimum CNR in the laboratory and the minimum CNR for OTA reception. In laboratory tests the minimum CNR for SFN has been determined to be 25dB⁴. Those laboratory tests were limited to quasi-static echoes with

Doppler shift of $\leq 0.05\text{Hz}$ (the Doppler shift generated by a walking person or strong winds is approximately 1.6Hz), no pilot cancellation and no symbol cancellation. Those limited laboratory tests showed that at least 10dB noise margin over the 15dB threshold SNR must be reserved for the equalizer processing for reliable reception in a quasi-static network environment.

For OTA reception, approximately an additional 10dB can be estimated for the required increase of the minimum CNR as follows⁵:

TXs noise addition $\approx 3\text{dB}$ when two signals are at 0dB

Man-made noise $\approx 2\text{dB}$

Tx and Rx antennas transfer function $\approx 3\text{dB}$

External interference $\approx 0\text{dB}$

Flat fading $\approx 2\text{dB}$

Thus, the minimum signal power for OTA reception of quasi-static signals ($\leq 0.05\text{Hz}$) in SFN environment is -64dBm . For stronger dynamics ($> 0.05\text{Hz}$) higher signal power would be required. Ultimately, with strong dynamics either carrier recovery fails or the equalization-generated noise is too high, and the SNR falls below the 15dB Threshold because the CNR is too low.

B. Analysis of the Received Signal

The model assumes that the strongest amplitude, the desired, is normalized to 1. A second signal or echo with amplitude $r \leq 1$, the undesired, arrives at the Rx delayed T sec, shifted by arbitrary ϕ degrees and possibly Doppler shifted by f_D .

⁴ Y. Wu et.al., "ATSC Receiver Behavior in a single Frequency Network Environment," 60th Annual IEEE Broadcast Symposium, October 20-22, 2010.

⁵ O.Bendov et.al, "Planning Factors for Fixed and Portable DTTV Reception," IEEE Trans. On Broadcasting, Sept. 2004.

1. Static Undesired

If the undesired signal's amplitude r and its delay T , the received amplitude is:

$$X_S(t) = \text{Cos}2\pi ft + r\text{Cos}[2\pi f(t+T) + \phi]$$

In complex form:

$$Y_S(t) = [1 + re^{j\phi} e^{j2\pi fT}] e^{j2\pi ft}$$

The resultant power as a function of frequency is:

$$|Y|_S^2 = 1 + r^2 + 2r\text{Cos}[2\pi fT + \phi]$$

The phase as a function of the channel frequency is:

$$\theta_S = \text{Tan}^{-1} \frac{r\text{Sin}[2\pi fT + \phi]}{1 + r\text{Cos}[2\pi fT + \phi]}$$

Since f and T are constants, the instantaneous frequency shift is:

$$F_S = \frac{d\theta}{2\pi dt} = 0$$

The group delay as a function of the channel frequency is:

$$\tau_s = -\frac{d\theta}{2\pi df} = -rT \frac{r + \text{Cos}[2\pi fT + \phi]}{1 + r^2 + 2r\text{Cos}[2\pi fT + \phi]} \quad \tau_{S\text{MAX}} = -rT \frac{r-1}{(1-r)^2}$$

Figure 3 shows how a single static undesired signal (or echo) distorts the 6MHz channel's spectrum filtered by a raised-cosine function. The delay was adjusted to create destructive self-interference at

Figure 3: Channel 37 Distortion by a Static Echo

When the Echo is Doppler shifted the shown distortion crawls depending on the echo delay
 When the Echo is static the distortion is static
 The loss of CNR is relative to the coherent sum of signal+echo

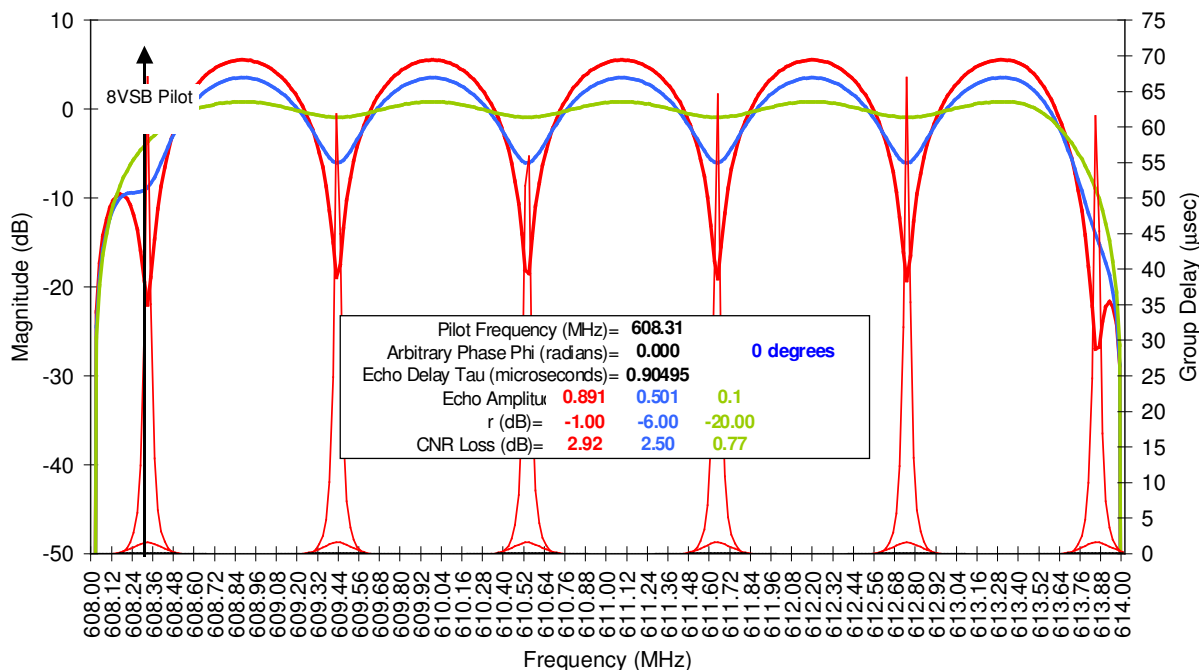

the pilot. To manage the shown deep notches in the spectrum and the significant group delay, two equalizers work in tandem. The frequency-domain equalizer flattens the spectrum, and the time-domain equalizer processes the remainder amplitude and group delay distortion.

2. Dynamic Undesired

If the undesired is dynamic, the resultant amplitude is:

$$X_D(t) = \text{Cos}2\pi f t + r \text{Cos}[2\pi(f \pm f_D)t + \phi]$$

where f_D is the Doppler shift of frequency resulting from a dynamic T.

In complex form:

$$Y_D(t) = [1 + r e^{j\phi} e^{j2\pi(\pm f_D)t}] e^{j2\pi f t}$$

The resultant power as a function of frequency is:

$$|Y|_D^2 = 1 + r^2 + 2r \text{Cos}[2\pi(\pm f_D)t + \phi]$$

The phase as a function of the channel frequency is:

$$\theta_D = \text{Tan}^{-1} \frac{r \text{Sin}[2\pi(\pm f_D)t + \phi]}{1 + r \text{Cos}[2\pi(\pm f_D)t + \phi]}$$

The instantaneous frequency shift as a function of the Doppler shift is:

$$F_D = \frac{d\theta}{2\pi dt} = r f_D \frac{r + \text{Cos}[\pm 2\pi f_D t + \phi]}{1 + r^2 + 2r \text{Cos}[\pm 2\pi f_D t + \phi]} \quad F_{D\text{MAX}} = r f_D \frac{r - 1}{(1 - r)^2}$$

When $f_D=0$, the resultant phase is constant as a function of elapsed time. Thus, the instantaneous frequency shift of the pilot as shown in **Figure 2** can only result from dynamic signals, but modulation of the pilot's amplitude results from either static (arbitrary ϕ) or from dynamic undesired signals.

Figure 4 shows how the pilot's magnitude (left Y-axis) and instantaneous frequency (right Y-axis) vary with the dynamics of a single undesired signal (or echo). The Doppler shifted undesired signal must not be too fast or too strong so as not to exceed the convergence speed and passband of the carrier recovery loop.

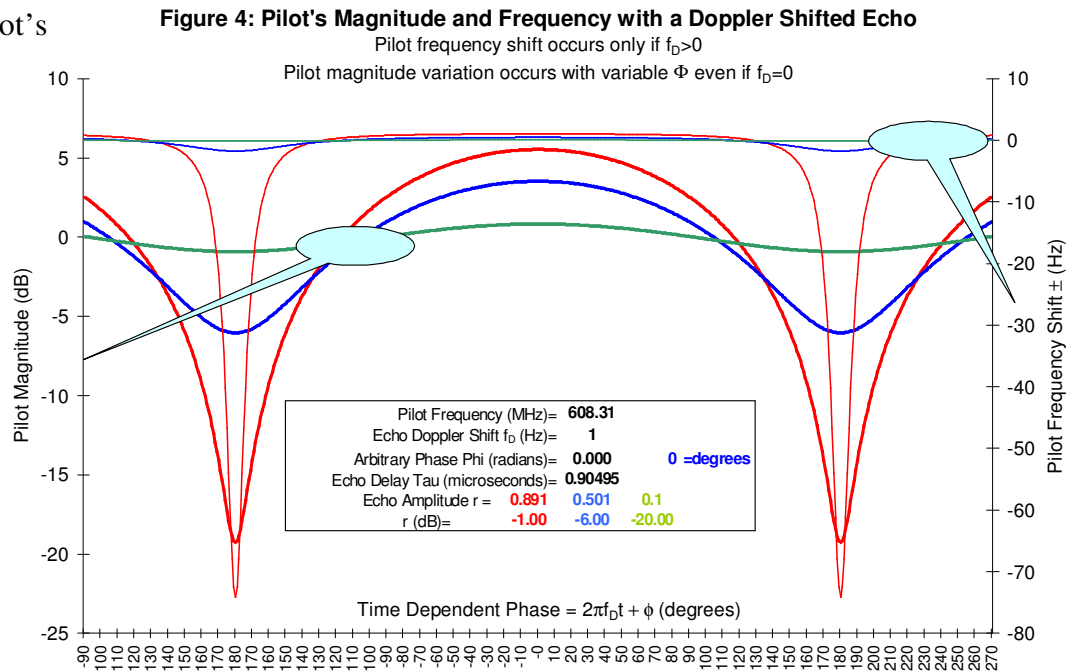

C. CNR Loss Due to Static Distortion

When a single undesired signal distorts the spectrum of the 6MHz channel, the relative loss of CNR (rather than SNR after equalizer correction) is:

$$\Delta CNR(dB) = 10\text{Log} \left[\frac{(1+r)^2}{BW} \int_{-BW/2}^{+BW/2} |H(f)|^2 df \right] - 10\text{Log} \left[\frac{1}{BW} \int_{-BW/2}^{+BW/2} |Y(f)|^2 |H(f)|^2 df \right]$$

where $Y(f)$ is the amplitude of the spectral distortion and $H(f)$ is the root raised-cosine filter.

If the undesired arrives with identical amplitude, phase, frequency and delay then the combined power $|Y(f)|^2 = (1+1)^2 = 4$ and $\Delta CNR = 0\text{dB}$.

The loss of CNR varies greatly with a differential delay and phase. The loss is highest when the delay is short and the relative phase is 180° . **Figure 5a** shows the loss of CNR for a short echo delay, adjusted for a notch at mid-channel, with a phase set to 180° . At the notch, the group delay is very high for a 0dB undesired signal.

Figure 5a: Channel 37 Distortion by a Static Echo
 When the Echo is Doppler shifted the shown distortion crawls depending on the echo delay
 When the Echo is static the distortion is static
 The loss of CNR is relative to the coherent sum of signal+echo

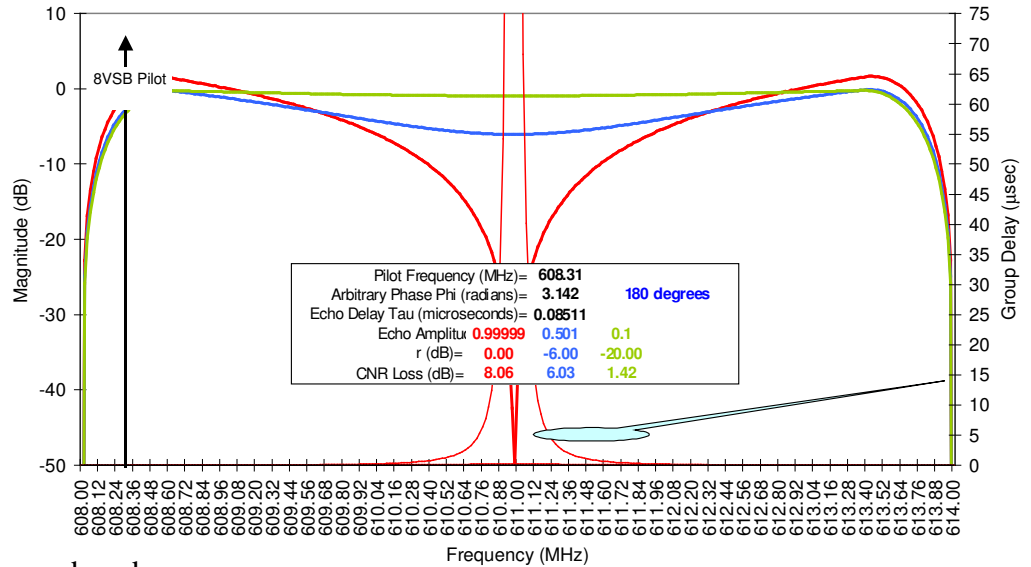

With a phase reversal of the same echo, shown in **Figure 5b**, the loss of CNR is at near zero and there is no group delay. For these two extreme cases, the loss of CNR could vary between 0 and ∞ (total loss of power), when the two signals are at 0dB without delay and either in or out of phase.

Figure 5b: Channel 37 Distortion by a Static Echo
 When the Echo is Doppler shifted the shown distortion crawls depending on the echo delay
 When the Echo is static the distortion is static
 The loss of CNR is relative to the coherent sum of signal+echo

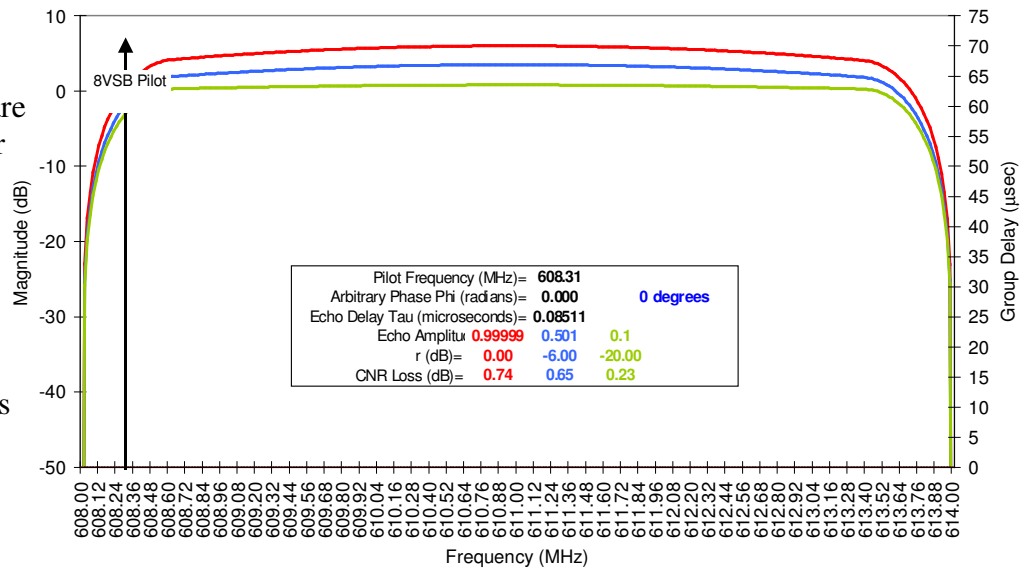

For a delay longer than $0.186\mu\text{Sec}$, the loss of CNR as shown in **Figures 6a** and **6b**, is approximately 3dB for 0dB undesired signal regardless of the phase differential.

Figure 6a: Channel 37 Distortion by a Static Echo

When the Echo is Doppler shifted the shown distortion crawls depending on the echo delay
 When the Echo is static the distortion is static
 The loss of CNR is relative to the coherent sum of signal+echo

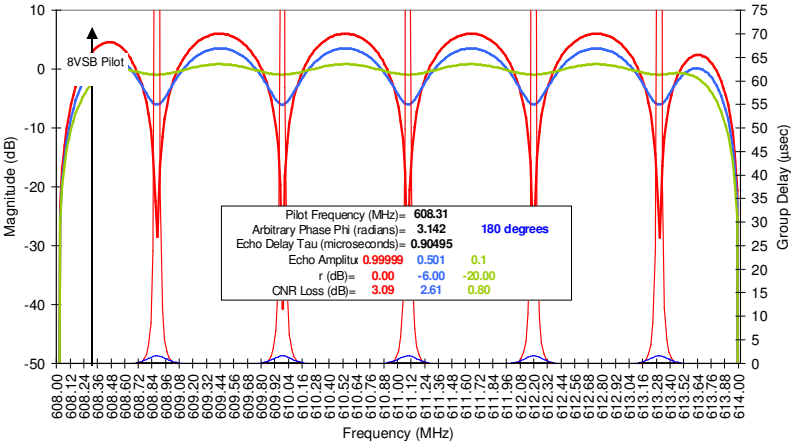
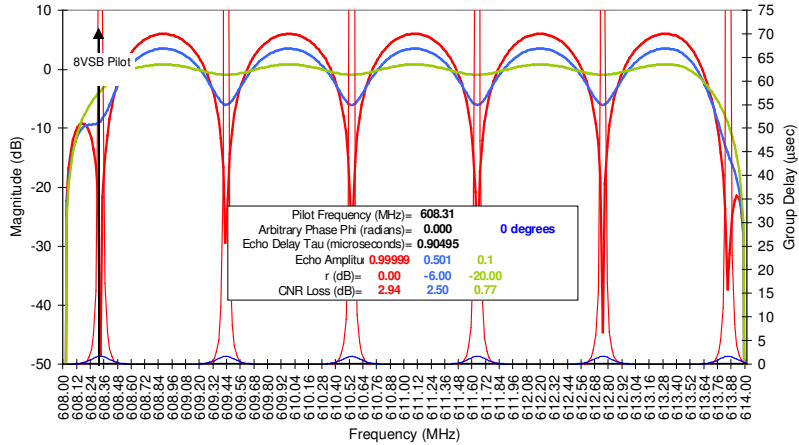

Figure 6b: Channel 37 Distortion by a Static Echo

When the Echo is Doppler shifted the shown distortion crawls depending on the echo delay
 When the Echo is static the distortion is static
 The loss of CNR is relative to the coherent sum of signal+echo



The loss of CNR shown in **Figures 5 and 6** was calculated using numerical integration for a fixed delay. An analytical approximation for all delays, assuming a rectangular pulse with bandwidth $\Delta F = 5.381\text{MHz}$ and mid-channel frequency f_0 is:

$$\Delta\text{CNR}(dB) = 10\text{Log}(1+r)^2 - 10\text{Log}\left\{1+r^2 + 2r \frac{\sin(\pi\Delta F\tau)}{\pi\Delta F\tau} \text{Cos}(2\pi f_0\tau + \phi)\right\}$$

where the term $\text{Sin}(\pi\Delta F\tau)/(\pi\Delta F\tau)$ is the Fourier transform of the rectangular pulse.

Figure 7 shows the exact calculation of CNR loss for the rectangular pulse for delays between 0 and $0.2\mu\text{Sec}$. It shows how the CNR varies when identical symbols, static or dynamic, overlap.

During the overlap period the autocorrelation of identical symbols causes the CNR to vary wildly.

This calculation confirms that for differential delay that is less than two symbol periods, $\tau = 1/\Delta F = 0.186\mu\text{Sec} = 56$

meters at channel 37, and moderate to large undesired signal, the loss of CNR could be severe depending on the relative phase between the two received signals. This loss of CNR applies to any two identical signals or echoes within an ensemble so long as their delay relative to each other is less than 56 meters. That is probably the main reason why indoor reception is so difficult for the ATSC-8VSB modulation. At greater delays the total power is the sum of the power of each signal, which is lower than the maximum power that would be available if the two signals were added coherently. For 0dB undesired the CNR loss outside the correlation period is $\approx 10\text{Log}[(1^2+1^2)/(1+1)^2] = -3\text{dB}$. Note that as ΔF gets narrower the correlation period becomes longer and when $\Delta F=0$, i.e. single unmodulated carrier, the CNR loss does not diminish.

Figure 7: CNR Loss at Channel 37 Due to Single Static Echo

Echo Levels: 0dB, -6dB, -20dB
 Rectangular Pulse 5.381MHz wide

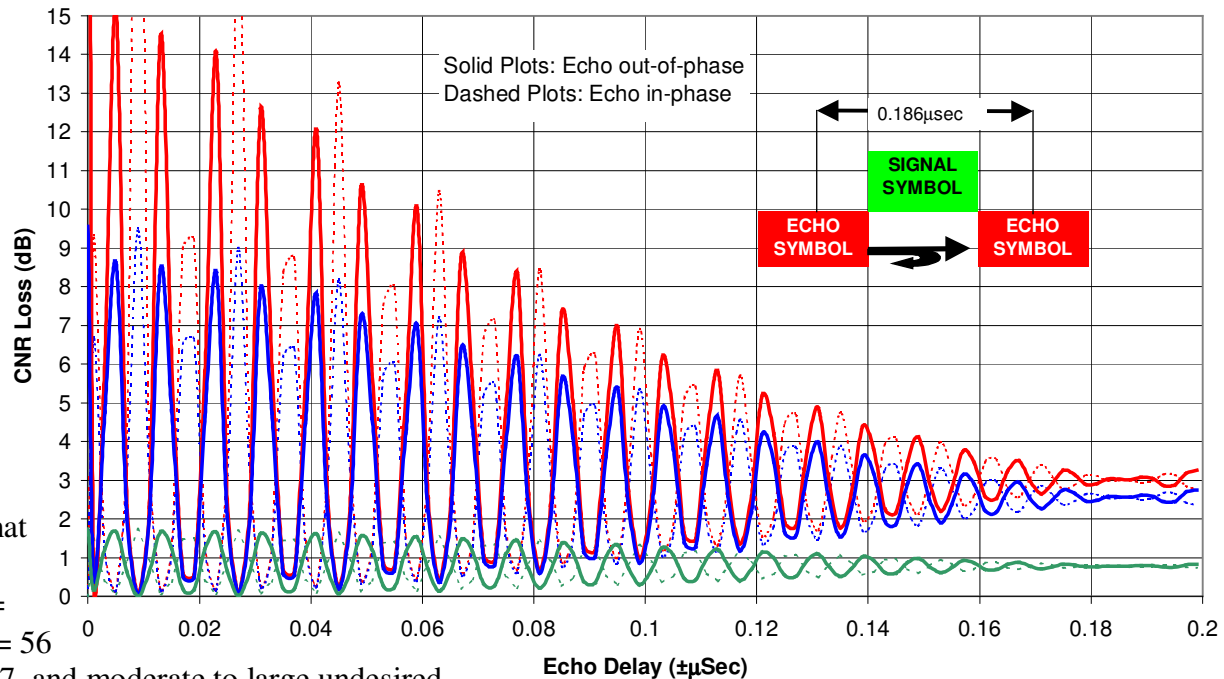
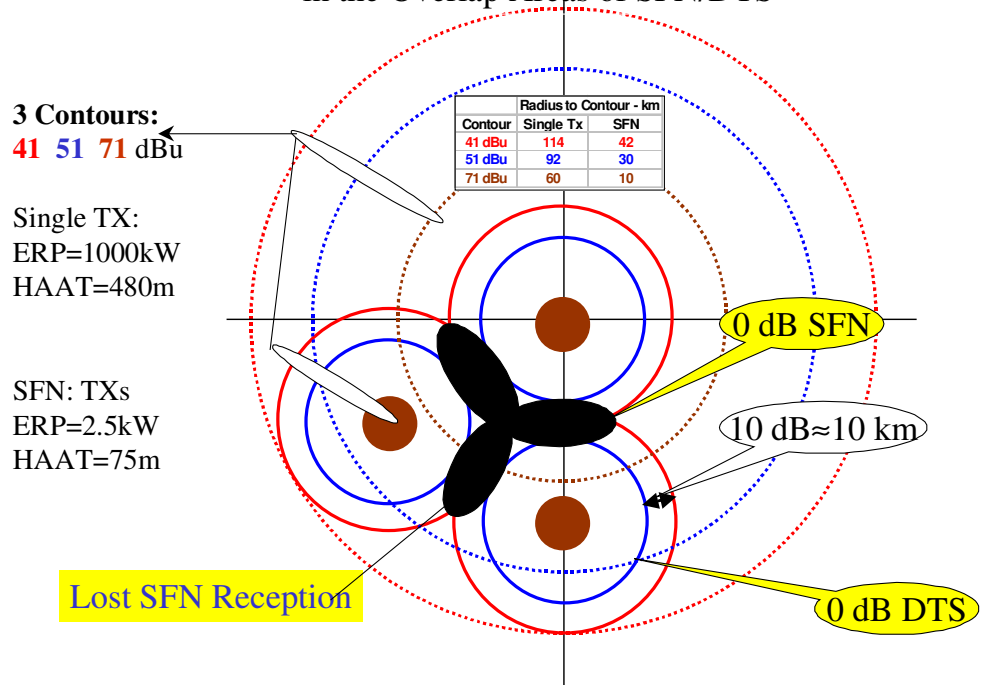

Figure 8: Relative Magnitude of Signals in the Overlap Areas of SFN/DTS



D. Extreme Signals and Echoes in SFN and DTS Networks

By design, the relative magnitude of overlapping signals, strong and weak, would be 0dB at many points within the service area. The FCC defines the service area as the area that is bounded by the thermal noise limiting contour (NLT). But in reality, the service area is the area bounded by the Radio Horizon (RH) as there is generally no reliable DTV reception beyond the RH for household antennas at $\leq 30'$ above flat terrain.

An example of 0dB points, assuming NLT as defined by the FCC for UHF channel, is shown in **Figure 8**. The use of F(50,90) here is only to illustrate that multiple signals with 0dB differential in magnitude exist in SFN/DTS by design. It should be noted the F(X,Y), the FCC's propagation algorithm, is a log-normal distribution that applies only to the attenuation of a single carrier without multipath and it should not be used to predict the interaction of multiple on-channel signals. In multipath environment, the joint probability distribution of signals with echoes should be used.

As shown in **Figures 3 and 4**, when the relative magnitude of an echo or an undesired signal is $r = -1$ dB, the group delay and instantaneous frequency shift increase rapidly even for a small Doppler shift. And as shown in **Figure 7**, when the path delay between the two is short, the loss of CNR can be very severe for 0dB and out-of-phase signals. Since the ATSC defines a -6 dB echo as "moderate," it is reasonable to define stronger echoes as "severe" in the context of ATSC-8VSB reception.

It is therefore instructive to examine the worst case of frequency shift, group delay and power loss

Figure 9: Worst CNR Loss at Channel 37 for Rectangular Pulse 5.381 MHz
Echo/Undesired Signal at 0 delay and out-of-phase
CNR loss relative to coherent addition of Desired and Echo/Undesired

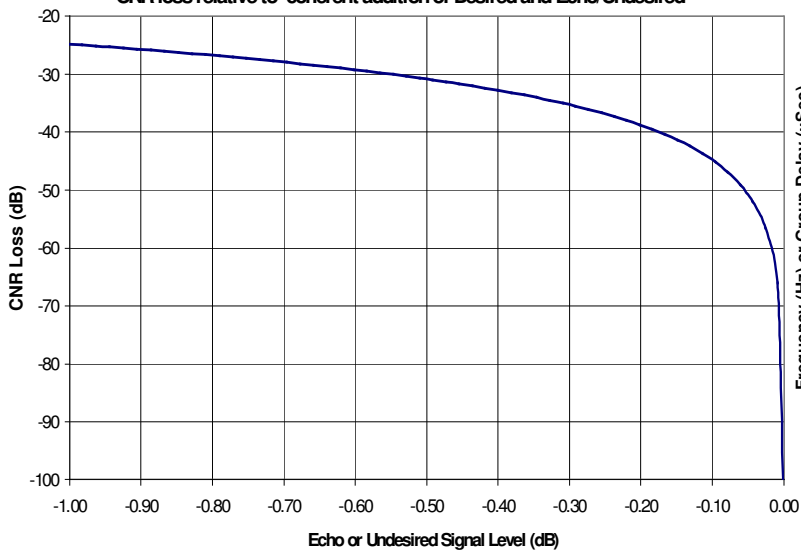
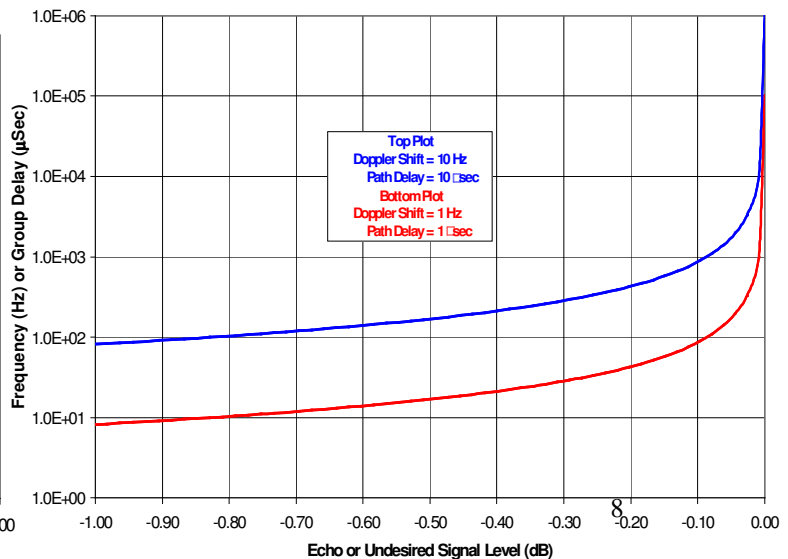

Figure 10: Worst Case Spectral Frequency Shift and Group Delay



when the desired signal is interfered with by an undesired with a relative magnitude between 0 and -1dB. **Figure 9** shows the expected loss of CNR for out-of phase static signals with no delay. **Figure 10** shows the expected carrier frequency shift for dynamic (Doppler shifted) signals.

E. Defining the Geographic Area of Where 0dB Signals Overlap

In **Section A** the minimum signal required for SFN was established at -64dBm and in **Section B** it was shown that near 0dB signals or echoes, static or dynamic, could be detrimental to SFN operation. In particular, it was shown in **Section C** that moderate to extreme signals or echoes with less than 1µsec delay result in severe loss of CNR.

Figure 11: PDF of Received Amplitude at 0±1.5km
K=20 (-20dB Echo) Primary attenuation=1dB/km

The loss of CNR and SNR caused by near 0dB signals and echoes is inherent to SFN/DTS designs based on the ATSC-8VSB single-carrier modulation. That is so because, in addition of loss of CNR at the input to the tuner, the equalizer at best attenuates the undesired if the carrier recovery and equalization are successful. But severe and dynamic echoes and signals are not always attenuated because the equalization and carrier recovery cannot be ideal.

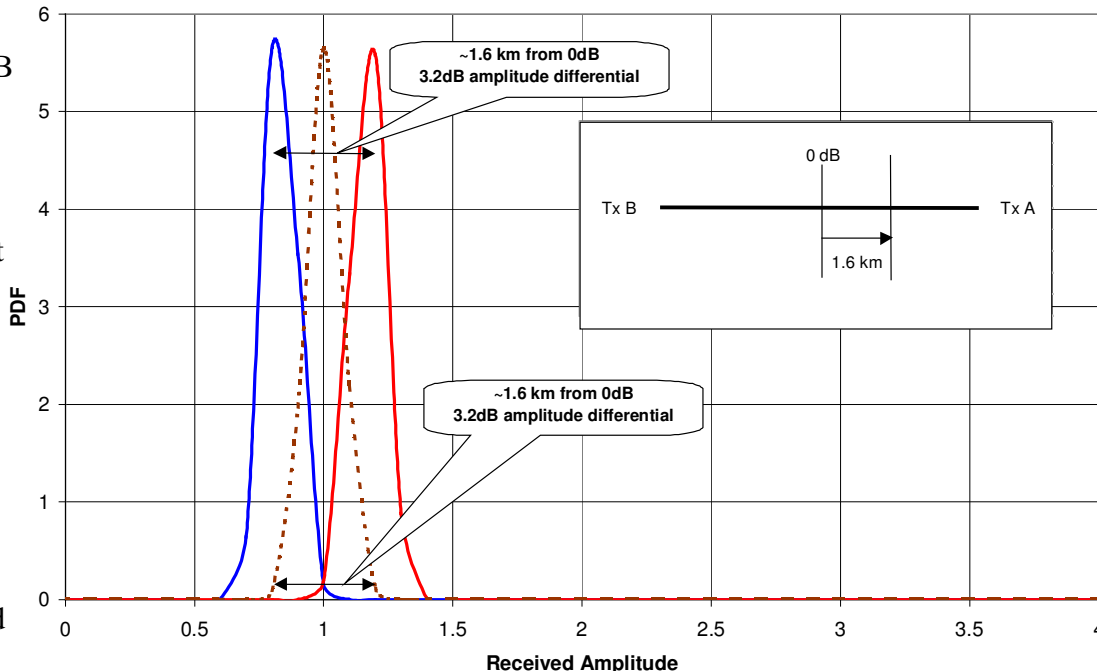
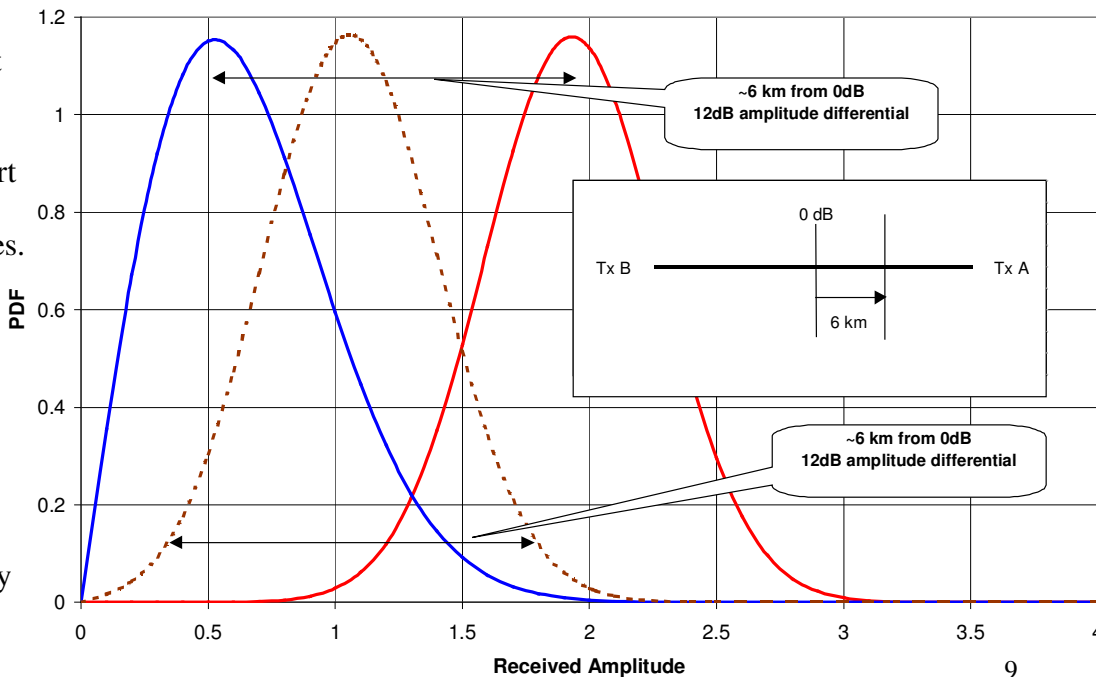

Figure 12: PDF of Received Amplitude at 0±6km
K=6 (-6dB Echo) Primary attenuation=1dB/km

In this section, the Rayleigh statistics that characterize reception throughout the service area of SFN using short towers is applied to two signals with echoes. The statistics of a signal with echoes is detailed in the **Appendix**.

Figure 11 shows how the signals from two identical transmitters overlap at 0dB midway between the two. For



the purpose of illustration the transmitters are synchronous and their propagation paths are identical. Each signal is associated with very low -20dB echo power. The attenuation is assumed to be $1\text{dB}/\text{km}$ and the echo statistics to be constant along the path from A to B.

At a point 1.6km from the midpoint toward A, signal A is stronger by 1.6dB and signal B is weaker by 1.6dB for a total difference of 3.2 dB . At this point there is no significant overlap of near 0dB signals. Thus for two signals, each with -20dB total echo power, there would be only a narrow geographic area, approximately $\pm 1.6\text{km}$ in width, where 0dB signals would overlap.

As the level of echo power increases, the geographic area in which severe overlap can occur becomes wider. As **Figure 12** shows, when the echo power increases from -20dB to -6dB , the geographic area where 0dB signals could overlap widens to $\pm 6\text{km}$. In a Rayleigh environment, where the total echo power is 0dB relative to the dominant signal, the geographic area widens to $\pm 12\text{km}$ (≈ 15 miles). This result agrees with a paper published earlier⁶ where a different approach to determining the required isolation between the desired and undesired signals was taken.

F. Design Example: Three-towers VHF-SFN in Urban Area

A DTV channel 10 (192-198MHz) transmitting omnidirectional 50kW from a height of 1000 feet is a candidate for replacement of its single tall tower with SFN using three equally-spaced towers, each 300 feet tall.

The terrain is assumed to be relatively flat but the obstructions, natural and man-made, are such that together with the short towers the environment of echoes and multiple signals can be characterized as Rayleigh everywhere in urban areas. As stated earlier, in a predominant Rayleigh environment, the receive antenna, even with directional pattern, cannot discriminate against undesired signals because in Rayleigh environment the angles of arrival are randomly distributed.

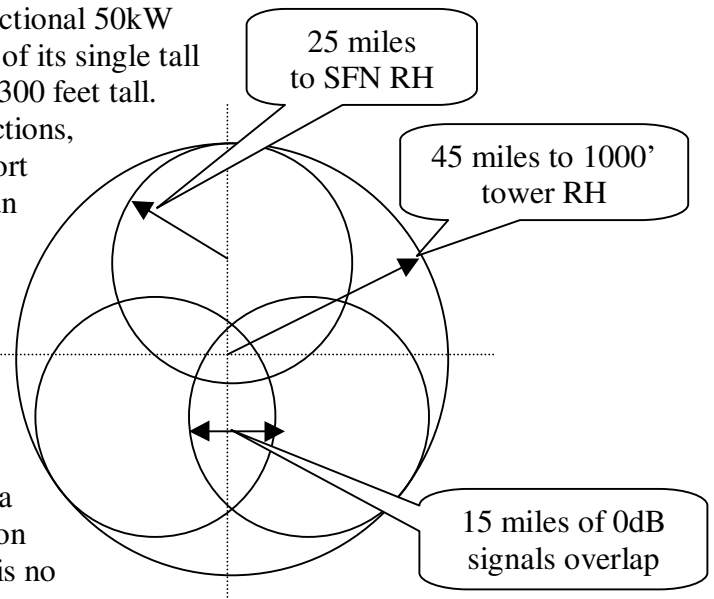

Figure 13: The Service Areas Defined by the RH of a Single Transmitter and SFN

Figure 13 is an example of a three-cell SFN designed as a replacement for the single tall tower used by a DTV station in the VHF band. Beyond the Radio Horizon (RH) there is no reception of analog or digital DTV regardless of what the FCC’s propagation algorithm decries, and that well-known fact is the starting point of this design. For the single transmitter and flat terrain, the RH is

approximately at 45 miles and the incident field strength at that RH from the 50kW transmitter would be approximately 55dBu . For the SFN, the RH is approximately at 25 miles and the incident field strength at that RH from a 5kW transmitter would also be approximately 55dBu . The second well-known fact that is incorporated in this design is that Rayleigh statistics characterize the reception environment if the SFN deploys transmitters on short towers in an urban environment, thus creating zones of 0dB overlap by signals and their echoes. The width of that overlap zone, as shown in **Figure 13**, is 14.9 miles ($\pm 12\text{km}$) per **Section E**.

⁶ O. Bendov, “Self-interference and Loss of SNR within Overlapped Coverage Areas of ATSC On-channel Distributed Transmitters,” available at tvantenna.tv

A designer may choose to increase the number of cells to more than three. Increasing the number of SFN cells would dictate shorter towers and thus more severe reception environment. It will also dramatically increase the cost of building and maintenance of such a network.

The attenuation algorithm used to calculate the incident field 30 feet above ground at the RH is not of particular importance. For the single transmitter, F(L,T) algorithm could be used and for SFN, COST-HATA algorithm could be used. What is important is that the received level near the RH be at least -64dBm (see **Section A**). Using the well-known relationship

$$dBu + G_{Rx} (dB) = dBm + 75.073 + 20\text{Log}f_{MHz}$$

that relates the incident field level in dBu and the received power level in dBm with an antenna of known gain, shows that the minimum of -64dBm received power condition for SFN has been met in the above design.

Comparing the coverage area of this SFN design with that of the single transmitter's, what has been gained and lost? The area covered by this SFN, excluding the 910sq.mi area where 0dB signals overlap is 4980sq.miles, and the area covered by the single transmitter is 6362sq.miles. Therefore, the coverage area of this SFN is $(4980/6362)=0.78$ of the area covered by the single transmitter. The electric bill for the three SFN transmitters would be significantly lower and the operational cost of three towers with synchronized transmitters may be higher than that of a single tower. But the loss of revenue due to the reduced SFN coverage and service may be unacceptable.

The reality is that even if the 0dB signals overlap area inside the RH is only 910 sq.miles, the remaining service area of each of the SFN towers is a Rayleigh environment dominated by strong echoes. In contrast, the service area of the single tall tower is characterized as Rician, in which moderate echoes inside the RH are predominant and in which the Rayleigh environment is restricted to indoor and urban canyons.

G. Conclusions

The designer of SFN must take into consideration the significant increase in echo power due to the lower height of the transmitting towers. The more cells and thus shorter towers, the more intense the level of echoes should be expected. The designer must also recognize that in addition to the 0dB echoes environment there is also 0dB active signals environment where the signals from two or more transmitters overlap. The results of the analysis presented here show that:

- 1. The expected loss of covered area, comparing single tower with SFN, is estimated between 20-25% for VHF and UHF regardless of the number of towers used. The loss of covered area is the sum of the area beyond the RH and the area where 0dB signals overlap. It is not the same as the loss of service, which includes the non-overlapped area inside the RH but which service would be lost due to low tower heights.***
- 2. The use of the equalizer's (single static echo) amplitude/delay mask as a pass/fail template for validating SFN/DTS designs grossly understates the real loss of service. Among others, it ignores the critical relative phase between signals and echoes, especially between those with relative delay less than two symbol periods. The amplitude/delay mask template also ignores loss of SNR just prior to reaching the Threshold SNR.***

3. *The loss of service where 0dB signals and echoes exist, and in the areas beyond the RH, is essentially independent of the pattern or the gain of the receiver's antenna because the active signals and echoes are Rayleigh-distributed and their angle of arrival is random.*
4. *Dynamic 0dB signals will make synchronization and decoding of the ATSC-8VSB virtually impossible because the carrier recovery loop has limited bandwidth and because a large instantaneous shift in frequency cannot be recovered fast enough.*
5. *DTV Broadcasters and the FCC, traditionally concerned about harmful interference, should be aware that the expected loss of service generated by self-interference in SFN/DTS systems may exceed by a large margin that caused by interference from all other sources.*

For these reasons SFN for ATSC-8VSB can only be successful in a shielded terrain such that the transmitters are isolated from each other and no longer require synchronization. OFDM-based SFN could be successful in a flat terrain because in that system the multiplicity of echoes and active signals, by design, enhance the dominant signal instead of degrading it.

Appendix: Amplitude and Phase Statistics of Signal with Echoes⁷

For a signal with echoes, the joint Probability Density Function (PDF) for path delays longer than the correlation period of $\tau > 0.186 \mu\text{Sec}$ (see **Section C**), of the received amplitude Y and phase ϕ is:

$$PDF(Y, \phi) = \frac{Y}{2\pi r^2} e^{-(A^2 + Y^2 - 2YA \cos \phi) / r^2}$$

where A is the amplitude of the dominant signal and r is the amplitude of the randomly distributed echoes. The relative phase (see **Section B**) is $\phi = 2\pi fT + \phi$ for a static echo vector and $\phi = 2\pi fDt + \phi$ for a dynamic echo vector.

It is convenient to define ratio of the desired signal power D and the undesired echo power U (D/U) in terms of the parameter K :

$$K = \frac{D}{U} = \frac{A^2 / 2}{r^2} = \frac{\text{Dominant path power}}{\text{Multipath power}} \quad K(\text{dB}) = 10 \text{Log} \frac{D}{U}$$

In terms of K and A ,

$$PDF(Y, \phi) = \frac{KY}{\pi A^2} e^{-2K(A^2 + Y^2 - 2YA \cos \phi) / A^2}$$

When $D=U$ ($K=0\text{dB}$) the joint probability distribution is known as Rayleigh, the predominant distribution in urban areas when one or more transmitters radiate from short towers in urban setting and also indoors regardless of tower height. For $K>1$ ($U<D$) it is known as Rician, the predominant distribution outdoors in suburban and rural areas when a single transmitter radiates from a tall tower.

The probability density of the envelope amplitude Y in terms of A and $K(\text{dB})$ is:

$$PDF(Y) = \int_{-\pi}^{\pi} PDF(Y, \phi) d\phi = \frac{2Y * 10^{K/10}}{A^2} \exp \left\{ -10^{K/10} \left(1 + \left(\frac{Y}{A} \right)^2 \right) \right\} I_0 \left[\frac{2Y * 10^{K/10}}{A} \right]$$

where I_0 is the modified Bessel function of order 0.

⁷ N. Blaunstein and J. Bach Andersen, *Multipath Phenomena in Cellular networks*, Artech House, 2002.

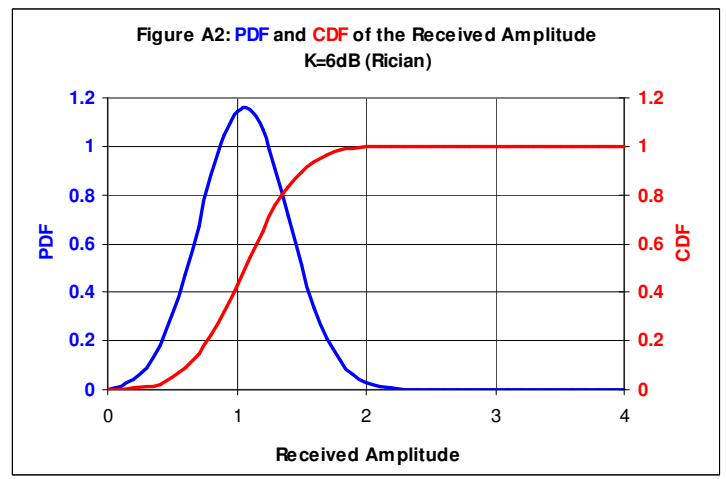
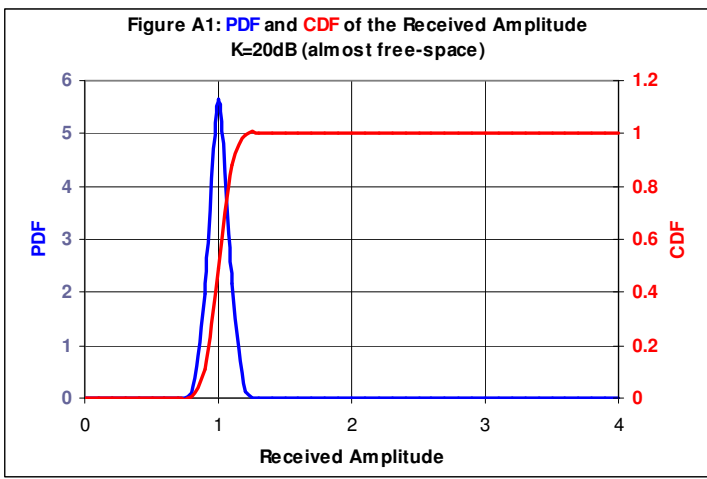

For $K=0\text{dB}$ (Rayleigh) and a dominant amplitude $A=1$,

$$PDF(Y, \varphi) = \frac{Y}{\pi} e^{-2(1+Y^2-2YA \cos \varphi)}$$

$$PDF(Y) = 2Ye^{-(1+Y^2)} I_0[2Y]$$

The Cumulative Distribution Function (CDF)

$$CDF(Y) = \int_0^Y PDF(x) dx$$

The PDF and CDF of a signal with echo power of 0dB (Rayleigh), -6dB (Rician) and -20dB (almost free-space) relative to the dominant signal are shown in **Figures A1-A3**. In **Figures A1-A3** the dominant signal amplitude $A=1$ and its power $A^2/2=1/2$.

As shown in **Figure A1**, when the echo power is -20dB , the dominant signal is well defined and the statistical spread of the received amplitude is small, approximately within $\pm 0.5\text{dB}$ for 80% of locations. Thus, the received signal amplitude, dominant + echo, is essentially the same as the dominant signal.

With moderate echo of -6dB , the uncertainty of the received amplitude increases to between -6dB to $+4\text{dB}$.

With 0dB echo, the uncertainty of the received amplitude increases to between -9dB to $+5\text{dB}$.

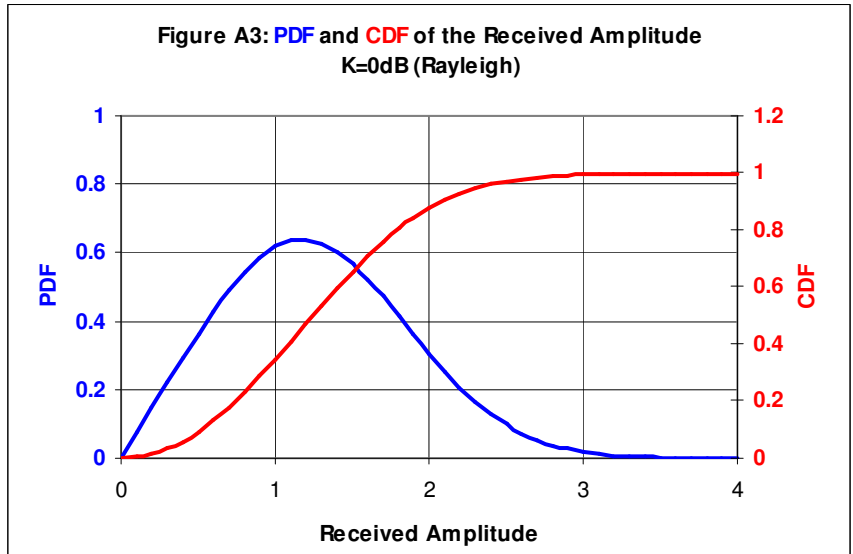

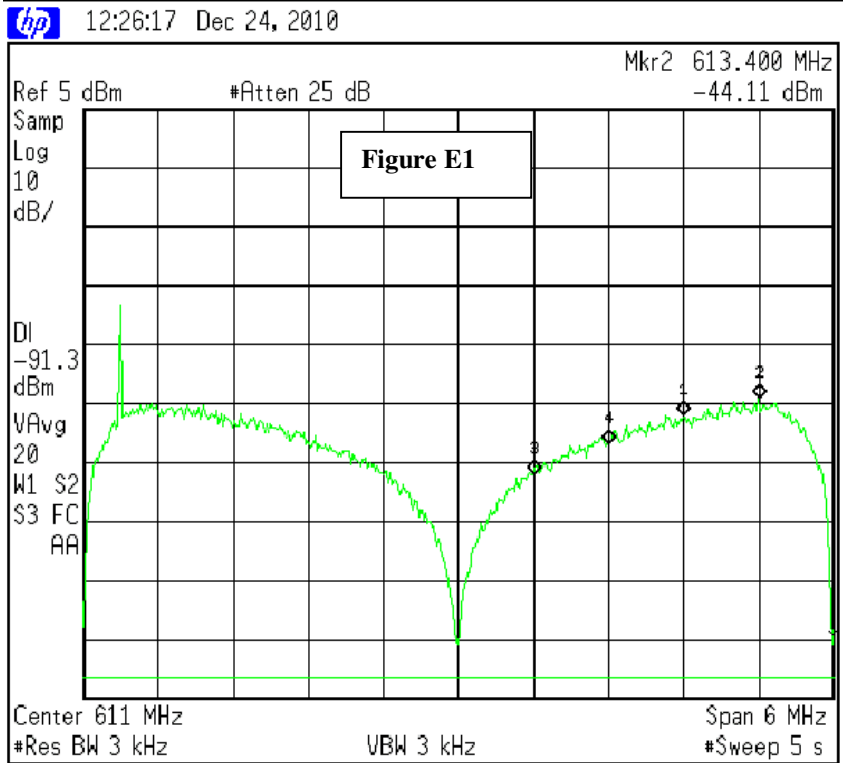

Experimental Results⁸
Figure E1: Confirmation of Figure 5a
 More experimental confirmations will be added when available.

⁸ Provided by Charles Rhodes and Linley Gumm